

Homework #6

Due: Friday, October 26, 2001

1. You have to design a system that receives as an input two 8-bit numbers (A[7..0] and B[7..0], coded in binary) and a control signal C, and outputs the largest or the smallest of the two input numbers if C=1 or 0 respectively.
 - a) If you design your system using a ROM, give the specifications of the chip you need.
 - b) Draw a schematic showing how would you connect the input and output signals.
 - c) For the case A=108, B=44, C=0, specify which is the address that would be accessed in the ROM (in hexadecimal), and which should be the content of the ROM (also in hexadecimal) in that address.

Solution

- a. System has $8+8+1 = 17$ inputs and 8 outputs. Therefore we need a ROM with 17 address lines and an 8-bit output word. Thus, we would need a $2^{17} \times 8$ (or 128k X 8) ROM chip.

- b. See figure at right

- c. The address is the concatenation of all the input bits.

A = 108d = 1101100b

B = 44d = 101100b

C = 0d = 0b

Address = 11011001011000b = 3658h

And at that address we should find the smaller of the two inputs, which was 44d.

Output = 44d = 2Ch

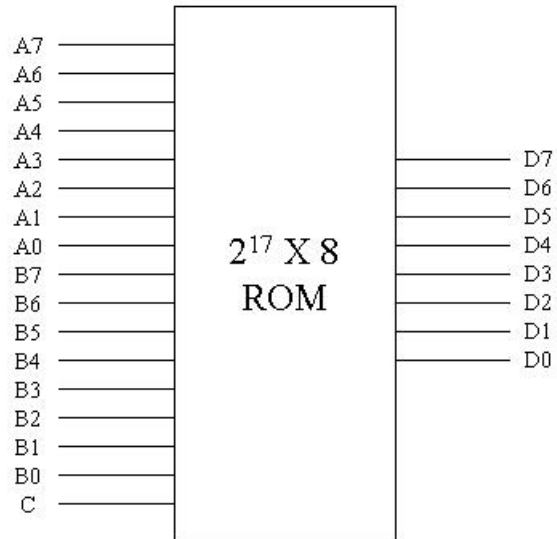

2. Somehow the ROM design of the previous problem doesn't satisfy your boss, so he asks you to use "those 4-bit comparators and 2:1 multiplexors that we have in stock". The comparators have two 4-bit inputs (X[3..0] and Y[3..0]) and two outputs: G indicates X>Y and E indicates X=Y. Design the system using the devices indicated by your boss (you can use a few additional gates). Hint: first use the 4-bit comparators to build an 8-bit comparator with only one output indicating A>B; after that, use the multiplexors to select the largest or smaller number.

Solution

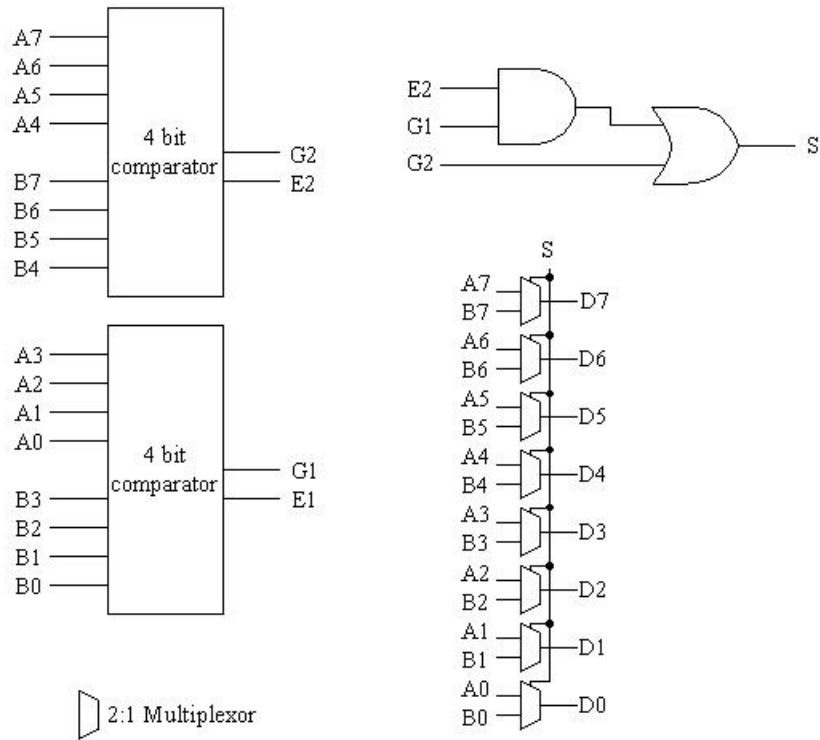

- Design a system that computes the parity bit of a 16-bit input (i.e., the output is 1 if the number of ones in the input is odd). Hint: design a 4-bit input parity generator and instantiate it many times.

Solution

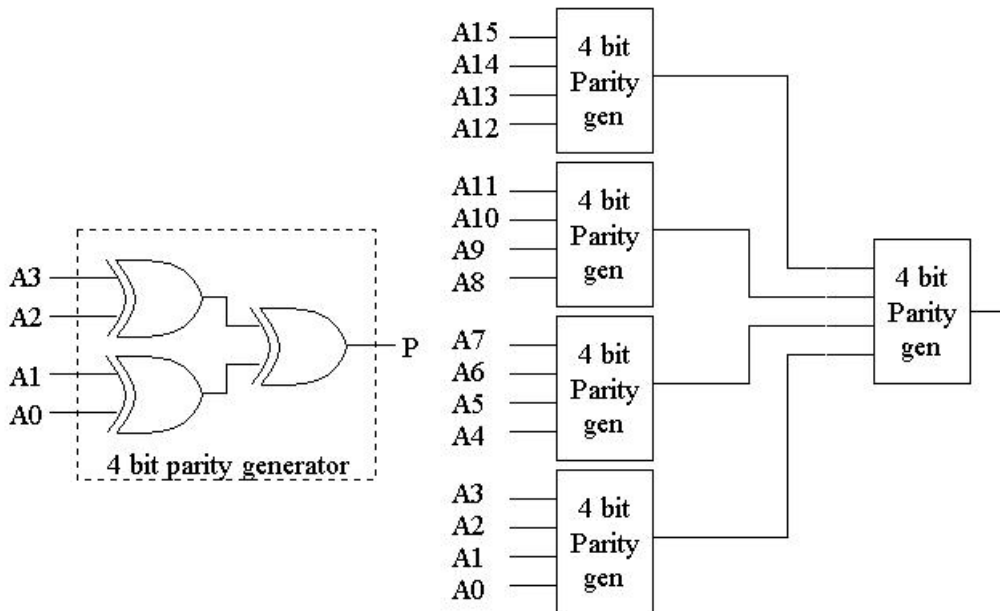

4. You have to design a system with one 3-bit input $N[2..0]$, and a 5-bit output $M[4..0]$ such that $M=3*N$.
- Find the minimum sum of products expression of the output.
 - If the system is to be implemented using a PLA, give the specifications of the chip you need. Draw a schematic of a PLA indicating the connections needed to implement the function.
 - Repeat part b) in case you are using a PAL.

Solution

a)

N2	N1	N0	M4	M3	M2	M1	M0
0	0	0	0	0	0	0	0
0	0	1	0	0	0	1	1
0	1	0	0	0	1	1	0
0	1	1	0	1	0	0	1
1	0	0	0	1	1	0	0
1	0	1	0	1	1	1	1
1	1	0	1	0	0	1	0
1	1	1	1	0	1	0	1

$$\begin{array}{c}
 \begin{array}{c} N2N1 \\ N0 \end{array} \quad \begin{array}{cccc} 00 & 01 & 11 & 10 \end{array} \\
 0 \quad \begin{array}{|c|c|c|c|} \hline & & 1 & \\ \hline & & 1 & \\ \hline \end{array} \\
 1
 \end{array}
 \quad M4 = N2.N1$$

$$\begin{array}{c}
 \begin{array}{c} N2N1 \\ N0 \end{array} \quad \begin{array}{cccc} 00 & 01 & 11 & 10 \end{array} \\
 0 \quad \begin{array}{|c|c|c|c|} \hline & & & 1 \\ \hline & 1 & & 1 \\ \hline \end{array} \\
 1
 \end{array}
 \quad M3 = N2.N1' + N2'.N1.N0$$

$$\begin{array}{c}
 \begin{array}{c} N2N1 \\ N0 \end{array} \quad \begin{array}{cccc} 00 & 01 & 11 & 10 \end{array} \\
 0 \quad \begin{array}{|c|c|c|c|} \hline & 1 & & 1 \\ \hline & & 1 & 1 \\ \hline \end{array} \\
 1
 \end{array}
 \quad M2 = N2.N1' + N2.N0 + N2'.N1.N0'$$

$$\begin{array}{c}
 \begin{array}{c} N2N1 \\ N0 \end{array} \quad \begin{array}{cccc} 00 & 01 & 11 & 10 \end{array} \\
 0 \quad \begin{array}{|c|c|c|c|} \hline & 1 & 1 & \\ \hline 1 & & & 1 \\ \hline \end{array} \\
 1
 \end{array}
 \quad M1 = N1.N0' + N1'.N0$$

$$\begin{array}{c}
 \begin{array}{c} N2N1 \\ N0 \end{array} \quad \begin{array}{cccc} 00 & 01 & 11 & 10 \end{array} \\
 0 \quad \begin{array}{|c|c|c|c|} \hline & & & \\ \hline 1 & 1 & 1 & 1 \\ \hline \end{array} \\
 1
 \end{array}
 \quad M0 = N0$$

b) We need a PLA with 3 inputs, 8 product terms and 5 outputs (this means, eight 6-input ANDs and five 8-input ORs).

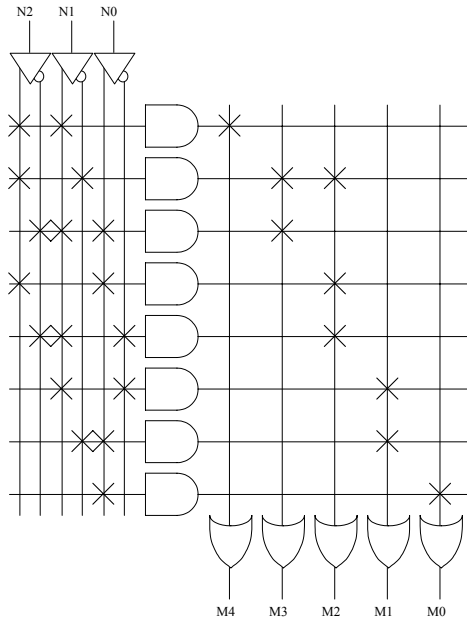

c) We need a PAL with 3 inputs, 3 product terms per output and 5 outputs (this means, $5 \times 3 = 15$ 6-input ANDs and five 3-input ORs).

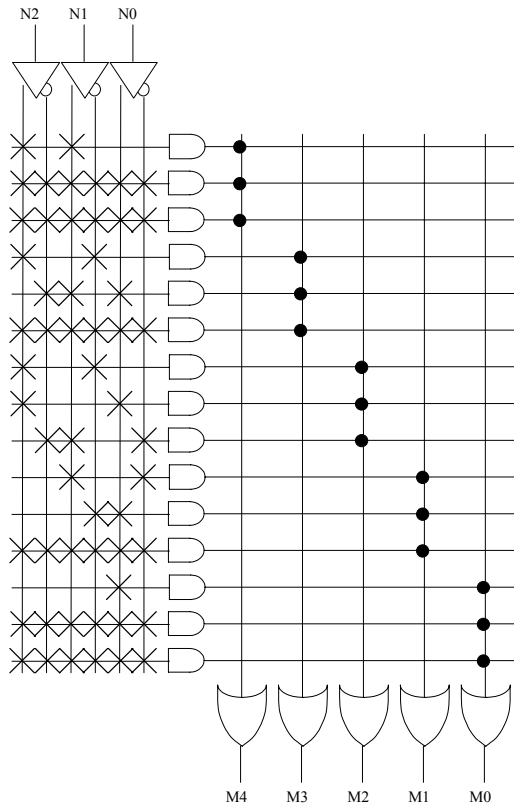

5. Design a 3-bit counter that can count in binary in increments of 1 or 2 units per clock cycle, depending on the value of a mode input M. Draw a state diagram, find the next state functions and draw a schematic of the circuit.

Solution

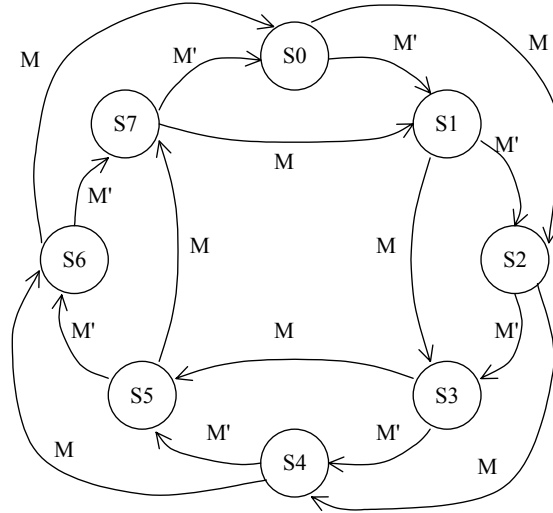

We will use the sequential state encoding (S0=000, S1=001, etc.), so the output is simply the current state.

CS2	CS1	CS0	M=0			M=1		
			NS2	NS1	NS0	NS2	NS1	NS0
0	0	0	0	0	1	0	1	0
0	0	1	0	1	0	0	1	1
0	1	0	0	1	1	1	0	0
0	1	1	1	0	0	1	0	1
1	0	0	1	0	1	1	1	0
1	0	1	1	1	0	1	1	1
1	1	0	1	1	1	0	0	0
1	1	1	0	0	0	0	0	1

M	CS2CS1				CS2CS1				CS2CS1			
	00	01	11	10	00	01	11	10	00	01	11	10
00	0	0	1	1	0	1	1	0	1	1	1	1
01	0	1	0	1	1	0	0	1	0	0	0	0
11	0	1	0	1	1	0	0	1	1	1	1	1
10	0	1	0	1	1	0	0	1	0	0	0	0

$$\begin{aligned}
 NS2 &= CS2.CS0'.M' + CS2'.CS1.CS0 + CS2'.CS1.M + CS2.CS1' \\
 NS1 &= CS1.CS0'.M' + CS1'.CS0 + CS1'.M \\
 NS0 &= CS0'.M' + CS0.M
 \end{aligned}$$

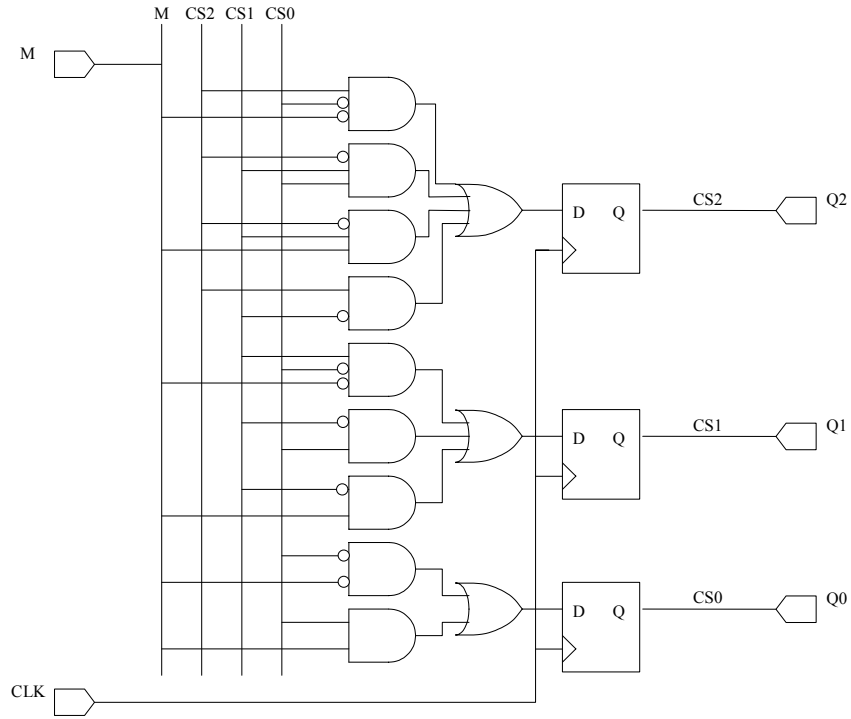

6. Problem 8.17 in the book.

Solution

a)

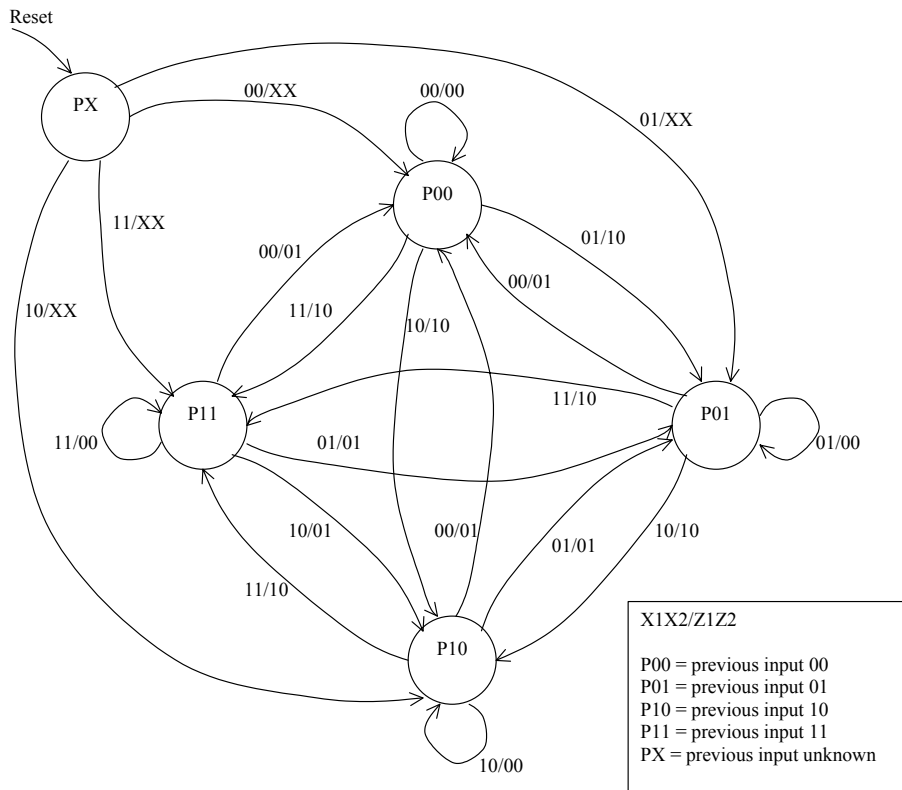

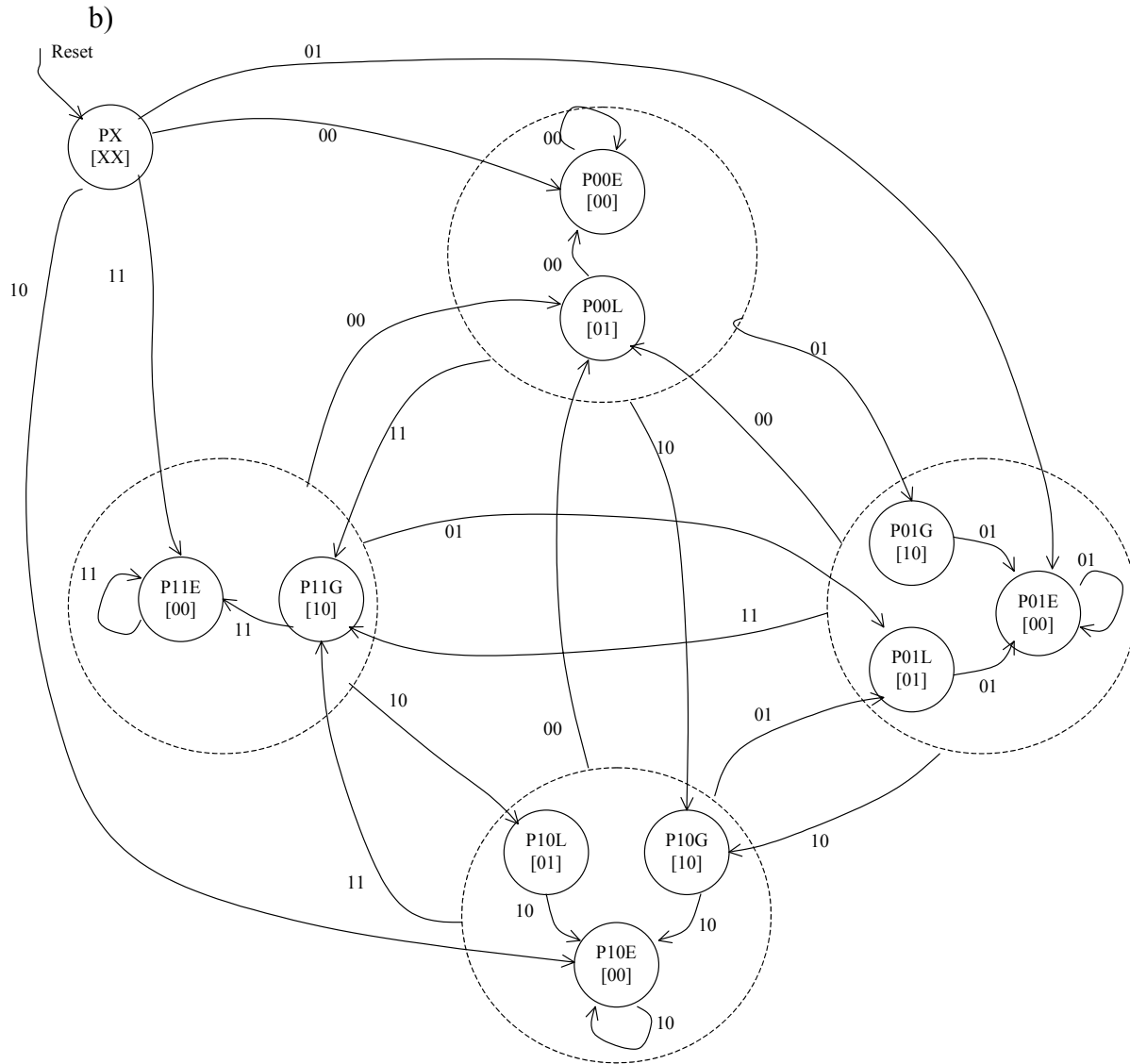

Note: In order to simplify the diagram, the arrows starting at the dotted circles represent arrows starting from every state in the circle.

Now every state has to remember not only the previous input, but also if the current input is greater, equal or less than the previous one (G, E and L respectively).